

RENISHAW 

RMP40

Radio Machine Probe



The **Renishaw RMP40** is the ideal choice for multi-tasking applications where the line-of-sight between probe and interface cannot always be maintained.

Benefits

- Reduced set-up & calibration routines provide more time for machining cycles
- Improved process control and quality
- Reduced, rework, concessions and scrap
- Less operator intervention
- Fast to install & easy to use
- Used with automatic tool changers

Features

- Touch trigger probe with proven kinematic design offering 1.00 μm 2 σ repeatability
- Secure frequency Hopping Spread spectrum (FHSS) technology
- Globally recognised 2.4 GHz waveband—compliant with radio regulations in all major markets
- Sealed to IPX8 for use in the harshest machining environments
- Compact probe design (40mm \varnothing x 40mm long)
- 360° transmission envelope for maximum configurability
- Wide variety of shanks to fit nearly all machining centers



Specifications

Specifications

Primary application	Workpiece inspection and job set-up on machining centers and multitasking machines.
Sense directions	$\pm X \pm Y + Z$
Trigger force XY low force XY high force +Z direction	0.50 N, 51 gf (1.80 ozf) 0.90 N, 92 gf (3.24 ozf) 5.85 N, 597 gf (21.04 ozf)
Sealing	IPX8 (EN/IEC 60529)
Unidirectional repeatability	1.00 μm (40 μin) 2σ

Battery Life (2 x AA 3.6 V lithiumthionyl chloride)

Stand-by Life	Continuous use
Dependent on switch-on/switch-off option	Dependent on switch-on/switch-off option
290 days	450hours

Renishaw Inspection Plus Software Cycles

- X or Y or Z single surface measure
- Web/pocket measure
- 4 point bore/boss measure
- Internal/external corner
- 3 point bore/boss vector measure
- Angled XY surface measure
- Holes on a pitch circle diameter (PCD) ie: Bolt hole patterns
- 4th axis measure. Can be modified for 4th and 5th axis applications
- Stock allowance
- Multi-stylus calibration with option to run multiple probes with different stylus angles
- Calibration on a ring or sphere available
- XYZ single surface vector measurement
- Optional software available for true 3D and form measurement

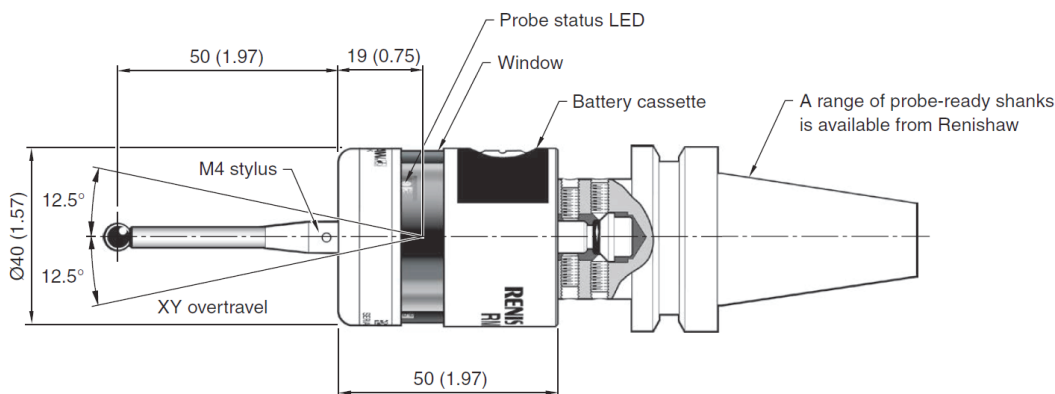

Productivity Quality, Inc.

15150 25th Avenue North, Suite 200
 Plymouth, MN 55447
www.PQIProbing.com
(800) 772-0620

